

P250

TOP LOAD CASEPACKER

Servo topload casepacker provides precision product handling while meeting all sanitary and FDA validation requirements

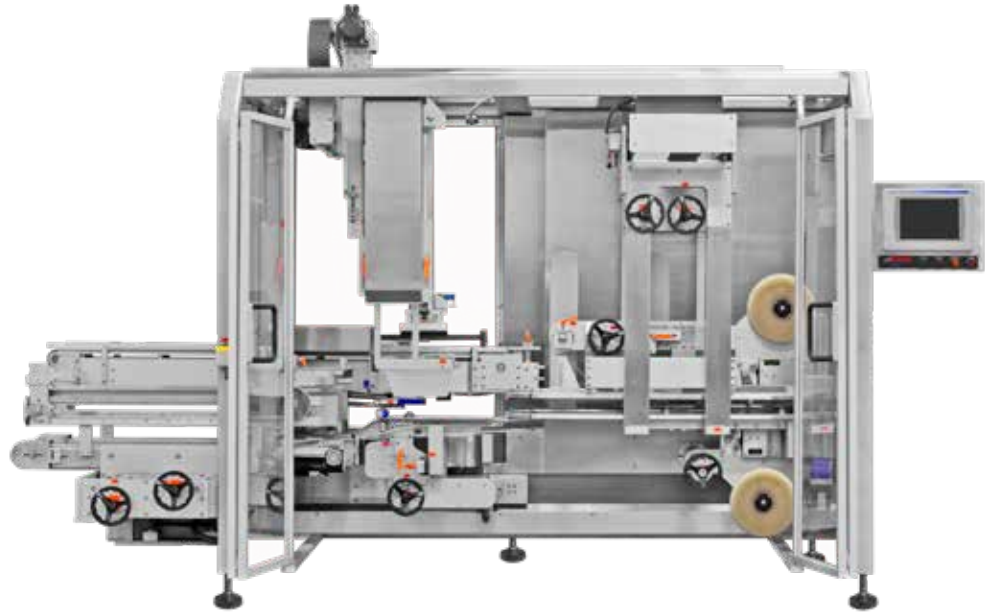

- All Servo Driven
- Balcony Design
- Compact Footprint
- All Belt Drives - low noise, longer life
- Unique Positive Dual Vacuum Case Erector
- Fast and Accurate Changeover - less than 5 minutes
- 2-axis servo pick & place
- Vacuum or gripper pick head with quick change tooling
- Low Maintenance - easy access to all components provides for easy maintenance
- User Friendly - fewer parts to time in
- Hot Glue or Tape Sealing
- **Validation Made Easy**

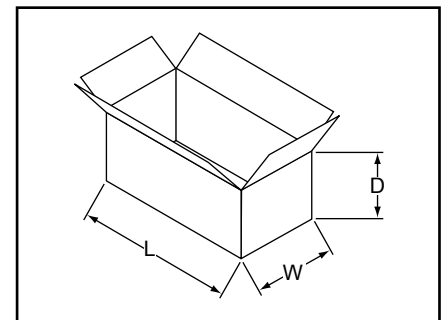

Case Range	Length	Width	Depth
Minimum	6" 152.4 mm	5" 127 mm	3" 76.2 mm
Maximum	18" 457.2 mm	12" 304.8 mm	12" 304.8 mm

Larger Ranges Available

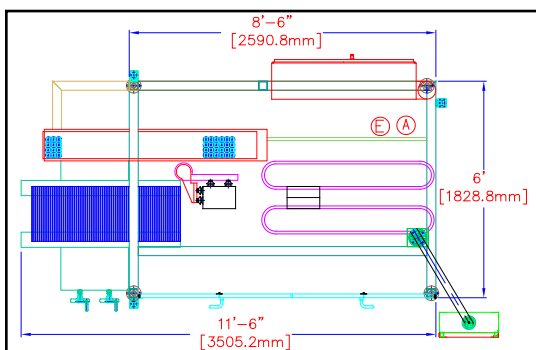

Standard Range Floorplan

SERPA

7020 W. Sunnyview Ave. • Visalia, CA 93291
 TEL: 559.651.2339 • FAX: 559.651.2345
 sales@serpapakaging.com
 www.serpapakaging.com