

# TEL 10

## TAMPER EVIDENT LABELER

A modular tamper-evident labeler that can be integrated with any packaging system

- Robust, compact design
- Quick-disconnect labeling heads
- Fast, accurate changeover
- Automatic changeover option available
- Low maintenance
- User-friendly
- Speeds up to 300 cartons per minute
- Straight or reverse tuck cartons
- Servo-driven labeling head
- Positive traction wheel for label folding
- Low level sensor for label roll

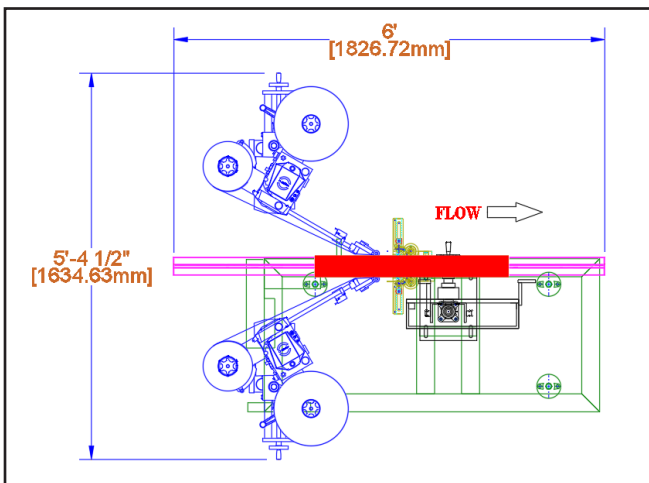
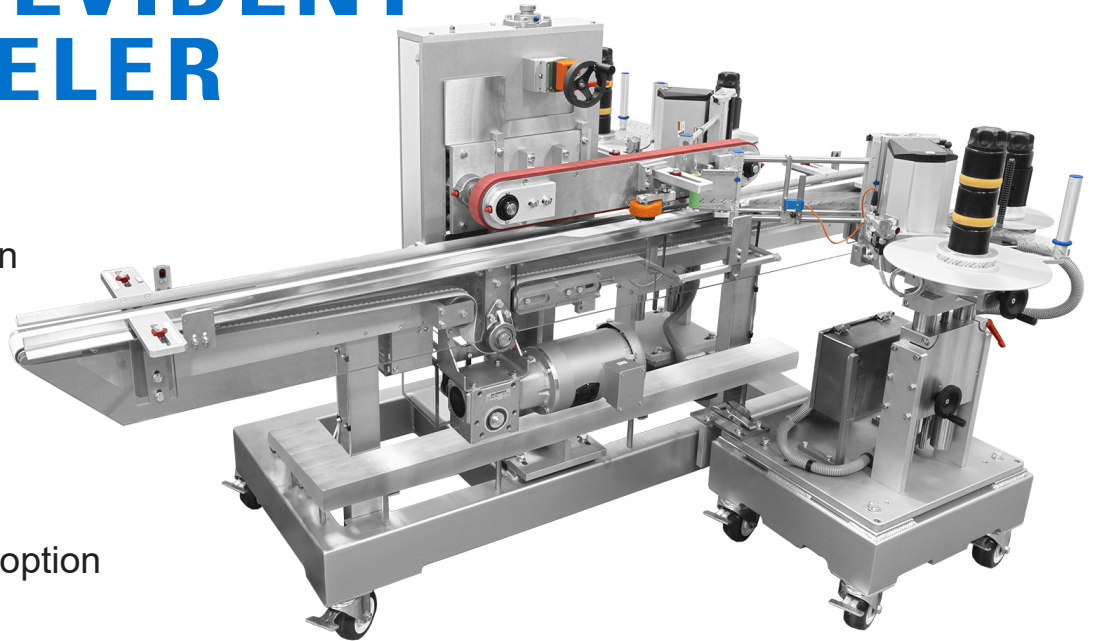

Standard Range Floorplan

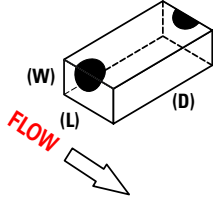
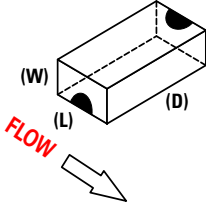
STRAIGHT TUCK		REVERSE TUCK	
			
Carton Range	Length	Width	Depth
Minimum	3/4" 19 mm	1" 25.4 mm	1.5" 38.1 mm
Maximum	12" 304.8 mm	4" 101.6 mm	7" 177.8 mm
Label Range	Length	Width	
Minimum	.2" 5 mm	.2" 5 mm	
Maximum	8" 203.2 mm	3.15" 80 mm	

Roll Size: 11.8" w/ 3" core center

**Larger Ranges Available**

# SERPA

7020 W. Sunnyview Ave  
Visalia, CA 93291

P: 559.651.2339 • F: 559.651.2345  
sales@serpapakaging.com  
www.serpapakaging.com

